



MEAT AND BACON PRESSES 8S

ABOUT DANFOTECH

Danfotech produces, installs, and services a wide range of machinery and specialized equipment for the food processing industry: bacon presses, defrosting lines, massaging tumblers, ham production lines, tenderizers, and loading/unloading systems built around cook tanks or ovens.

Additionally, Danfotech also delivers column lifts for Vemag trolleys and plastic tubs, as well as swing loaders for plastic tubs and trolleys.

+45 98 16 55 00

dftsales@danfotech.com

www.danfotech.com

Indkildevej 4M, DK-9210
Aalborg SØ, Denmark



MEAT AND BACON PRESSES SERVO FLEX PRESSES

The 8S Servo press is designed for automatic operation with 3 individual servos controlled by Shapetec™ press technology which secures the perfect compression and automatically flexes the height, based on the individual thickness of the product to be pressed.

- No hydraulics or cooling water
- Reduce operating cost & sanitation concerns

Automatic conveyors, with custom length, load, and discharge frozen bellies and integrate with existing production lines. The standard 8S Servo press is manually operated with both in-feed and discharge conveyors which can be integrated into a delivery form freezer as well as hand off to slicer or similar equipment.

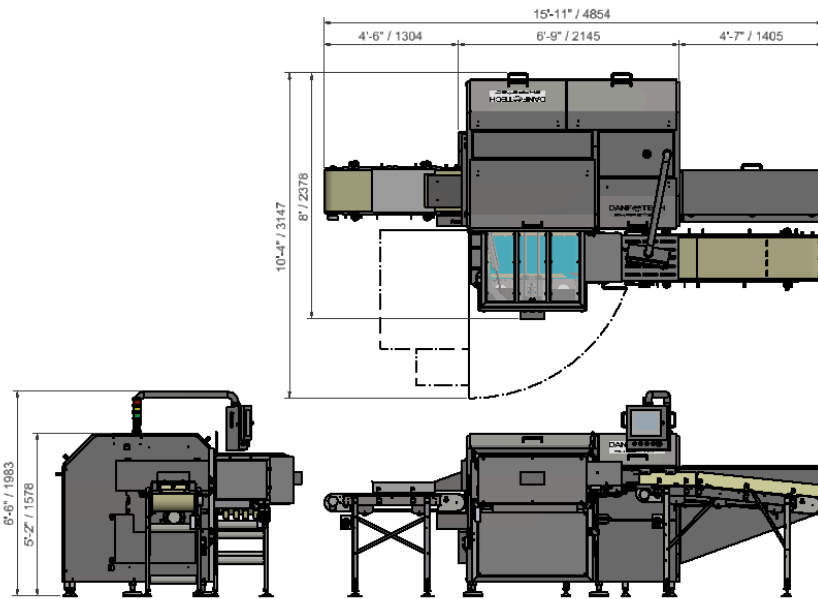

MEAT AND BACON PRESSES

SERVO FLEX PRESSES, SHAPETEC, TYPE 8S

8S IN NUMBERS

- Up to 8 cycles per minute
- Press available with auto in-feed conveyor, made to customer specification in length
- Press Chamber length 889 mm x 406 mm x 120 mm (35"x15,7"x4,7")
- Up to 20mm / .75" automatic flex
- Quick toolless die change in less than 5-7 min.
- 380V-460V x 3 phase 50Hz or 60 Hz
- 63 Amps
- Air pressure @ 100PSI or 7 bar

8S FEATURES

- All Servo operated
- No Water + No Hydraulics = No Contamination
- Largest & longest press chamber of any press in the industry
- Intelligent Shapetec™ Press Controls for customized compression control, wrinkle reduction, optimal shape, and maximum yields.
- 3 Directional pressing for better shape and yield opportunity
- Remote electrical cabinet, installed in dry area
- No water contamination
- Allen Bradley PanelView touch screen controls with visual troubleshooting assistance
- Maintenance check list with sign-off installed
- CE approved