



## MEAT AND BACON PRESSES

### 8-35

## ABOUT DANFOTECH

Danfotech produces, installs, and services a wide range of machinery and specialized equipment for the food processing industry: bacon presses, defrosting lines, massaging tumblers, ham production lines, tenderizers, and loading/unloading systems built around cook tanks or ovens.

Additionally, Danfotech also delivers column lifts for Vemag trolleys and plastic tubs, as well as swing loaders for plastic tubs and trolleys.



+45 98 16 55 00



dftsales@danfotech.com



www.danfotech.com



Indkildevej 4M, DK-9210  
Aalborg SØ, Denmark



## MEAT AND BACON PRESSES

The standard 8-35 Hydraulic operated press is designed for Manual operation and includes a Powerful Hydraulic but gentle pressing system which secures the perfect compression of products. The Danfotech 8-35 presses bellies by means of a die-set, in shapes that correspond to the desired finished products.

The frozen meat or bellies is molded in the hydraulic operated press where it is exposed to a 3-dimensional pressure to attain uniform shape and quality for maximizing slicing yields.

The 8-35 can be delivered with a wide selection of easy interchangeable, snap-in die-sets available for a wide range of applications.

Bacon, various meats, plus a variation for "Loose Meat - Logs" production for Philly Cheese steaks. The 8-35 Press offers automatic infeed and discharge options with various auxiliary system. Automatic conveyors, with custom length, load, and discharge can be integrated with existing production lines.

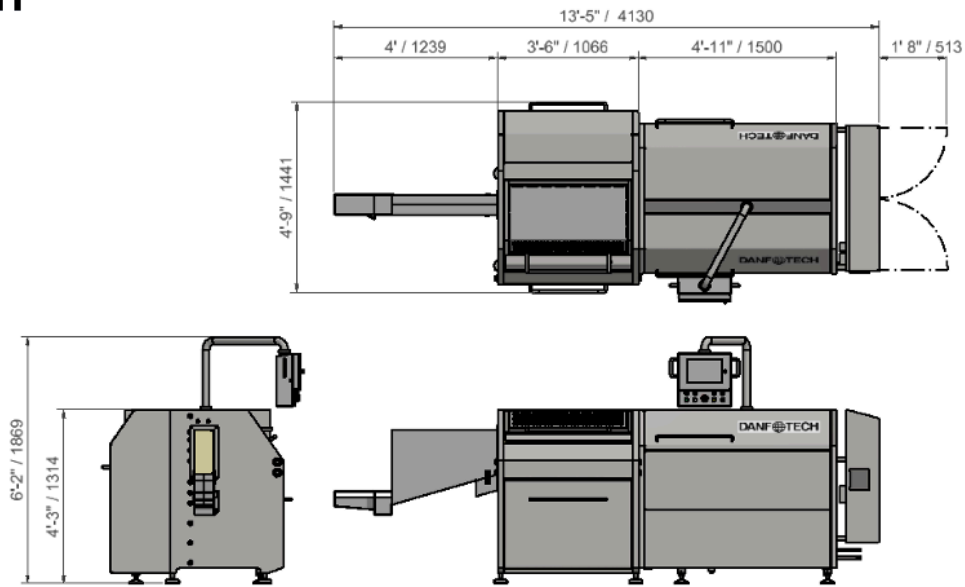

## MEAT AND BACON PRESSES

HYDRAULIC OPERATION, TYPE 8-35

### 8-35 IN NUMBERS

- Up to 8 cycles per minute
- Press available with optional in-feed conveyor and with a manual loading function.
- Press Chamber length 889 mm x 406 mm x 120 mm (35"x16"x4,7")
- Quick toolless die change in less than 5-7 min.
- 380V-460V x 3 phase 50Hz or 60 Hz
- 63 Amps
- Air pressure @100PSI or 7 bar

### 8-35 FEATURES

- The Powerful but gentle pressing System, Hydraulic operated
- Largest & longest press chamber of any press in the industry
- Press Controls for customized compression control, wrinkle reduction, optimal shape, and maximum yields.
- 3 Directional pressing for better shape and yield opportunity.
- Left and Right outfeed available
- Electrical cabinet, mounted on the unit
- Allen Bradley PanelView touch screen controls with visual troubleshooting assistance
- Maintenance check list with sign-off installed
- USDA Accepted and CE approved