**Patent Applied**

FIXED BLOCK PRESS

ABOUT DANFOTECH

Danfotech produces, installs, and services a wide range of machinery and specialized equipment for the food processing industry: bacon presses, defrosting lines, massaging tumblers, ham production lines, tenderizers, and loading/unloading systems built around cook tanks or ovens.

Additionally, Danfotech also delivers column lifts for Vemag trolleys and plastic tubs, as well as swing loaders for plastic tubs and trolleys.

Increased Flexibility and Control:

- Customize block size and shape to your needs
- Achieve perfect blocks for easy packaging, palletizing and freezing
- Ensure consistent quality and texture in your meat product

The frozen meat pieces are molded in the hydraulic operated press where it is exposed to a 1-dimensional pressure to attain a uniform shape.

The FBP press can be delivered with a selection of die sets available for a wide range of applications. The FBP press offers automatic in-feed and discharge options with various auxiliary systems.

Automatic conveyors and weighing hoppers, with custom length, load, and discharge can be integrated with existing production lines.

DANFOTECH FIXED BLOCK PRESS

The patented FBP Hydraulic operated block press is designed for automatic operation and includes a Powerful Hydraulic but gentle pressing system that secures the perfect compressing of the product. The Danfotech FBP presses loose meat using a die-set, in shapes that correspond to the desired finished product.

- +45 98 16 55 00
- dftsales@danfotech.com
- www.danfotech.com
- Indkildevej 4M, DK-9210 Aalborg SØ, Denmark



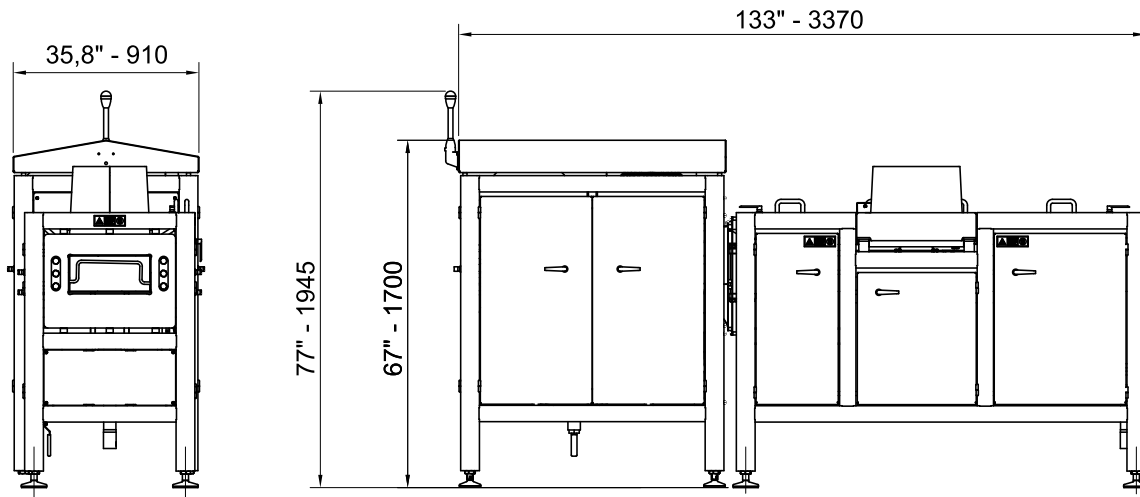

FIXED BLOCK PRESS

HYDRAULIC OPERATION, FBP

FBP IN NUMBERS

- 2 cycles per minute
- Press available with optional in-feed conveyor, weighing hopper, and out-feed conveyor
- Available in right-hand and left-hand models
- Press Champer length 800 mm x 480 mm x 178 mm (31,5" x 18,9" x 7")
- Block Size up to: 500 mm x 400 mm x 175 mm (19,7" x 15,7" x 6,9")
- 380V-460V x 3 phase 50Hz or 60Hz

FBP FEATURES

- The Powerful but gentle pressing System, hydraulic operated
- Press Controls for customized compression control
- Fixed Champer, one end press with variable controlled press
- Electrical cabinet, mounted on the unit or wall
- Allen Bradley Panel View touch screen controls with visual troubleshooting assistance
- Maintenance check list with sign-off installed
- USDA Accepted and CE approved