

# TENDERIZER

## KT140

## ABOUT DANFOTECH

Danfotech produces, installs, and services a wide range of machinery and specialized equipment for the food processing industry: bacon presses, defrosting lines, massaging tumblers, ham production lines, tenderizers, and loading/unloading systems built around cook tanks or ovens.

Additionally, Danfotech also delivers column lifts for Vemag trolleys and plastic tubs, as well as swing loaders for plastic tubs and trolleys.



+45 98 16 55 00



dftsales@danfotech.com



www.danfotech.com



Indkildevej 4M, DK-9210  
Aalborg SØ, Denmark



## TENDERIZER

### KT140

Using a tenderizer is an effective way of opening muscles and thereby increasing meat surfaces. This is essential to increase the absorption capacity of meat and thus the possibility of improving assimilation of additives and subsidiary substances. In the succeeding processes, the quantity of muscle proteins on meat surfaces is substantially increased.

1. Products are conveyed on a belt and drop into knife shafts, one of which is spring-activated.
2. Knives open muscle fibres, thereby enlarging meat surfaces.

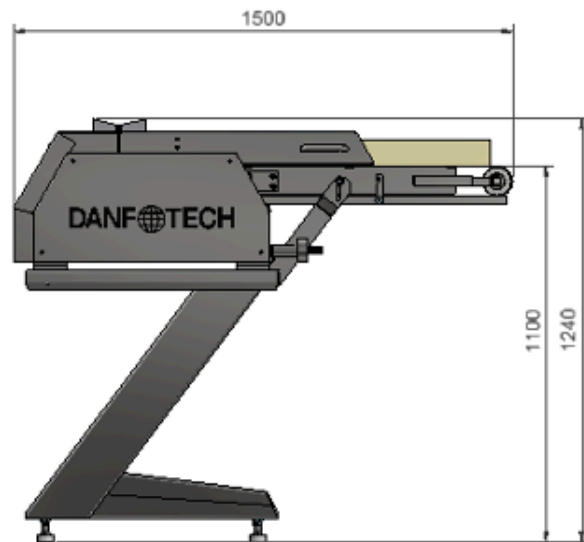
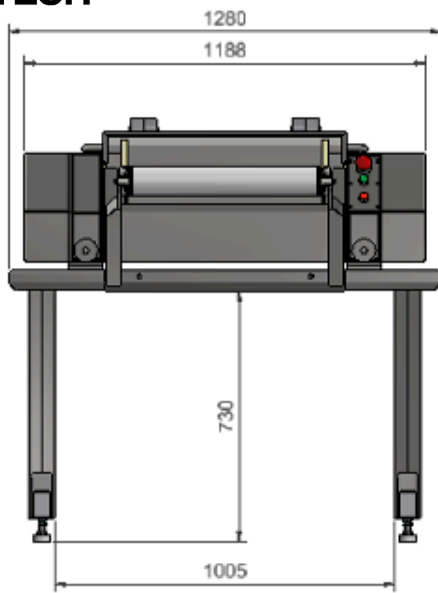

## **TENDERIZER KT140**

FOR PORK, BEEF, CHICKEN AND TURKEY

### TENDERIZER IN NUMBERS

- |                          |               |
|--------------------------|---------------|
| • Capacity.              | up to 10.000  |
| • Max. product height    | kg/hour       |
| • Number of knives       | 80 mm         |
| • Knife, diameter        | 153 pcs       |
| • Knife roller, distance | 138 mm        |
| • Working width          | -10 to +16    |
| • Motor                  | 550 mm        |
| • Voltage                | 3 kW          |
| • Control voltage        | 3x220/400/415 |
| • Weight, net            | /460          |
|                          | 24 VAC        |
|                          | Approx 500 kg |



\*knives

### TENDERIZER FEATURES

- The roller distance is adjustable to compensate for overlaps or the distance between knives.
- A blind roller can be installed for products with rind. (Option).
- Super-effective cleaning as the Tenderizer is equipped with knife shafts with distance parts for knives. This means that the knife shaft itself has an open structure, contrary to ordinary knife-roller tenderizers in the market. The open structure reduces daily cleaning by two hours compared to conventional types.
- Quick-lock system for conveyor cleaning.
- The tenderizer has a built-in retainer for easy handling of knife shafts during cleaning.
- The tenderizer conforms to the strictest rules regarding health and safety.
- The tenderizer is CE-marked and complies with the HACCP regulations.