



MEAT AND BACON PRESSES 6+

ABOUT DANFOTECH

Danfotech produces, installs, and services a wide range of machinery and specialized equipment for the food processing industry: bacon presses, defrosting lines, massaging tumblers, ham production lines, tenderizers, and loading/unloading systems built around cook tanks or ovens.

Additionally, Danfotech also delivers column lifts for Vemag trolleys and plastic tubs, as well as swing loaders for plastic tubs and trolleys.



+45 98 16 55 00



dftsales@danfotech.com



www.danfotech.com



Indkildevej 4M, DK-9210
Aalborg SØ, Denmark



MEAT AND BACON PRESSES

The standard 6+ Hydraulic operated press is designed for Manual operation and includes a Powerful Hydraulic but gentle pressing system which secures the perfect compression of products. Danfotech 6+ presses bellies using a die set in shapes that correspond to the desired finished products.

The frozen meat or bellies is molded in the hydraulic operated press where it is exposed to a 3-dimensional pressure to attain uniform shape and quality for maximizing slicing yields. The 6+ can be delivered with a wide selection of easy interchangeable, snap-in die-sets available for a wide range of applications.

The 6+ Press offers automatic infeed and discharge options with various auxiliary system. Automatic conveyors, with custom length, load, and discharge. Can be integrated with existing production lines.

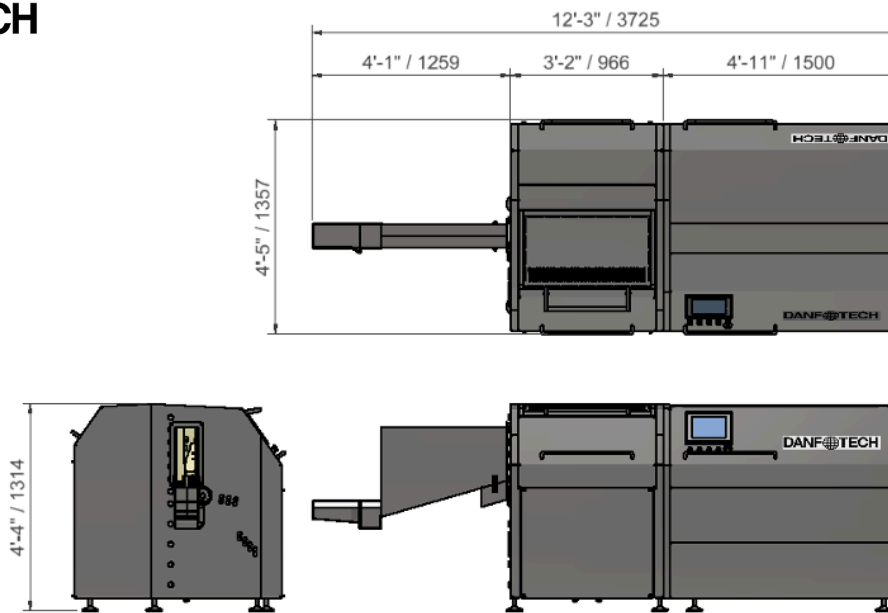

MEAT AND BACON PRESSES

HYDRAULIC OPERATION, TYPE 6+

6+ IN NUMBERS

- Up to 6 cycles per minute
- Press available with optional in-feed conveyor and with a manual loading function.
- Press Chamber length 790 mm x 406 mm x 120 mm (31"x16"x4,7")
- Quick toolless die change in less than 5-7 min.
- 380V-460V x 3 phase 50Hz or 60 Hz'
- 63 Amps

6+ FEATURES

- The Powerful but gentle pressing System, Hydraulic operated
- Largest & longest press chamber of any similar press in the industry
- Press Controls for customized compression control, wrinkle reduction, optimal shape, and maximum yields.
- 3 Directional pressing for better shape and yield opportunity.
- Electrical cabinet, mounted on the unit.
- Allen Bradley PanelView touch screen controls with visual troubleshooting assistance
- Maintenance check list with sign-off installed.
- USDA Accepted and CE approved.